

# 1.25Gbps 1550nm 100km SFP Optical Transceiver Module

## S-SP1G55LA0-xD

### Features

- Hot-pluggable
- 1.25Gbps operation
- +3.3V single power supply
- High-performance and cost-effective
- 1550nm LD and PIN photodetector for 100km trans-mission
- Compliant with SFP MSA and SFF-8472 with duplex LC receptacle
- Digital Diagnostic Monitoring
- Compatible with SONET OC-24
- Operating case temperature: 0 to +70°C  
-40 to +85°C
- RoHS compliant (lead free)

### Applications

- Gigabit Ethernet
- Gigabit Fiber Channel
- Switch to Switch interface
- Switched backplane applications
- Router/Server interface
- Other optical transmission systems

### Description

SFP transceivers are high performance, cost effective modules supporting 1.25Gbps and 100km transmission distance with SMF.

The transceiver consists of three sections: a 1550nm LD transmitter, a PIN photodiode integrated with a trans-impedance preamplifier (TIA). SFP modules satisfy class I laser safety requirements.

The transceivers are compatible with SFP Multi-Source Agreement (MSA) and SFF-8472. For further information, please refer to SFP MSA.

### Absolute Maximum Ratings

Parameter	Symbol	Min	Typ	Max	Unit
Power Supply Voltage	V <sub>cc</sub>	-0.5		4	V
Storage Temperature Range	T <sub>s</sub>	-40		85	°C
Relative Humidity - Storage	RH <sub>s</sub>	0		95	%
Relative Humidity - Operating	RH <sub>o</sub>	0		85	%

# 1.25Gbps 1550nm 100km SFP Optical Transceiver Module

## S-SP1G55LA0-xD

### Recommended Operating Conditions

Parameter	Symbol	Min	Typ	Max	Unit
Case Operating Temperature Range	T <sub>C</sub>	0	-	70	°C
		-40	-	85	
Power Supply Voltage	V <sub>CC</sub>	3.14	3.3	3.47	V
Supply Current	I <sub>CC</sub>	-	-	300	mA
Data Rate	BR	-	1.25	-	Gbps

### Electrical Characteristics

Transmitter Electrical Characteristics					
Parameter	Symbol	Min	Typ	Max	Unit
Differential Input Voltage Swing	V <sub>IN</sub>	400	-	2000	mV
Tx Differential Input Impedence	Z <sub>IN</sub>	-	100	-	Ω
Transmitter Disable Voltage	V <sub>DIS</sub>	2.0	-	V <sub>CC</sub> +0.3	V
Transmitter Enable Voltage	V <sub>EN</sub>	0	-	0.8	V
T <sub>FAULT</sub> Logic High	V <sub>TFH</sub>	2.4	-	V <sub>CC</sub>	V
T <sub>FAULT</sub> Logic Low	V <sub>TFL</sub>	V <sub>EE</sub>	-	V <sub>EE</sub> +0.4	V
Receiver Electrical Characteristics					
Parameter	Symbol	Min	Typ	Max	Unit
Differential output Voltage Swing	V <sub>OUT</sub>	400	-	1000	mV
Rx Differential Output Impedence	Z <sub>OUT</sub>	-	100	-	Ω
LOS Assert Voltage	V <sub>LOSA</sub>	2.4	-	V <sub>CC</sub>	V
LOS De-assert Voltage	V <sub>LOSD</sub>	V <sub>EE</sub>	-	V <sub>EE</sub> +0.4	V

### Optical Characteristics

Transmitter Characteristics						
Parameter	Symbol	Min	Typ	Max	Unit	Notes
Laser Type		LD				
Data Rate	-	-	1.25	-	Gb/s	
Center Wavelength Range	λ	1480	1550	1580	nm	
Spectral Width@-20dB	Δλ	-	-	1	nm	
Average Launch power of OFF transmitter	P <sub>OFF</sub>	-	-	-40	dBm	
Launch Optical Power	P <sub>out</sub>	0	-	5	dBm	1
Extinction Ratio	ER	9	-	-	dB	

# 1.25Gbps 1550nm 100km SFP Optical Transceiver Module

## S-SP1G55LA0-xD

Receiver Characteristics						
Receiver Type			PIN			
Data Rate	-	-	1.25	-	Gb/s	
Operating Central Wavelength	$\lambda$	1260	-	1610	nm	
Receiver Sensitivity	Sen	-	-	-28	dBm	2
Receiver Overload	P <sub>SAT</sub>	-3	-	-	dBm	
LOS Assert	LOSA	-35	-	-	dBm	
LOS De-Assert	LOSD	-	-	-28	dBm	
LOS Hysteresis	LOSH	0.5	3	5	dB	
Notes						
1. Average power figures are informative only, specified in IEEE802.3z						
2. Measured with 2 <sup>7</sup> -1 PRBS@1.25Gbps, BER<10 <sup>-12</sup>						

## General Specifications

Parameter	Symbol	Min	Typ	Max	Unit	Notes
Bit Rate	BR	-	1.25	-	Gb/s	
Bit Error Ratio	BER	-	-	10 <sup>-12</sup>		

## Pin Definitions

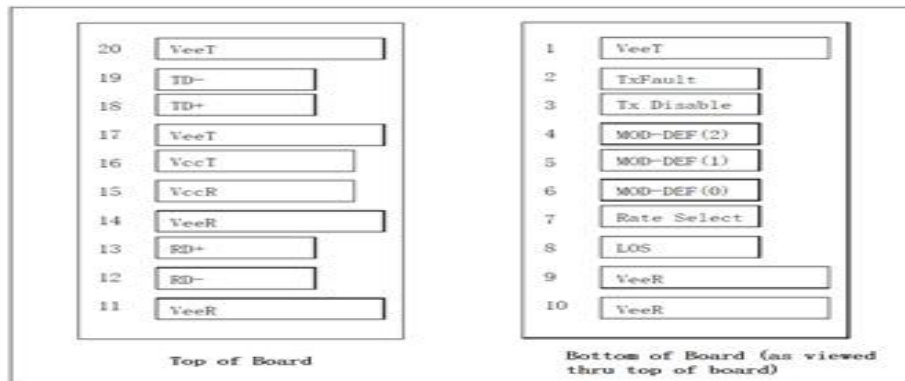

PIN Assignment			
PIN	Symbol	Description	Notes
1	V <sub>EET</sub>	Transmitter Ground	
2	Tx_FAULT	Transmitter Fault	1
3	Tx_DIS	Transmit Disable	1
4	MOD_DEF 2	Serial Data	1

# 1.25Gbps 1550nm 100km SFP Optical Transceiver Module

## S-SP1G55LA0-xD

5	MOD_DEF 1	Clock Signal	1
6	MOD_DEF 0	Interface Digital Ground	
7	Rate Select	Not Connected	
8	Rx_LOS	Receiver Loss of Signal	1
9	V <sub>EER</sub>	Receiver Ground	
10	V <sub>EER</sub>	Receiver Ground	
11	V <sub>EER</sub>	Receiver Ground	
12	RD-	Rx_Data Output (Inverted)	
13	RD+	Rx_Data Output (Non Inverted)	
14	V <sub>EER</sub>	Receiver Ground	
15	V <sub>CCR</sub>	Receiver DC Power	
16	V <sub>CCT</sub>	Transmitter DC Power	
17	V <sub>EET</sub>	Transmitter Ground	
18	TD+	Tx_Data Input (Non Inverted)	
19	TD-	Tx_Data Input (Inverted)	
20	V <sub>EET</sub>	Transmitter Ground	

### Notes

1. The uncommitted Tx\_Fault, Rx\_LOS, MOD\_DEF 1 and MOD\_DEF 2 LVTTTL monitor and control pins each require a pull up resistor of 4.7k to 10k Ohms on the host board.

### Recommended Interface Circuit

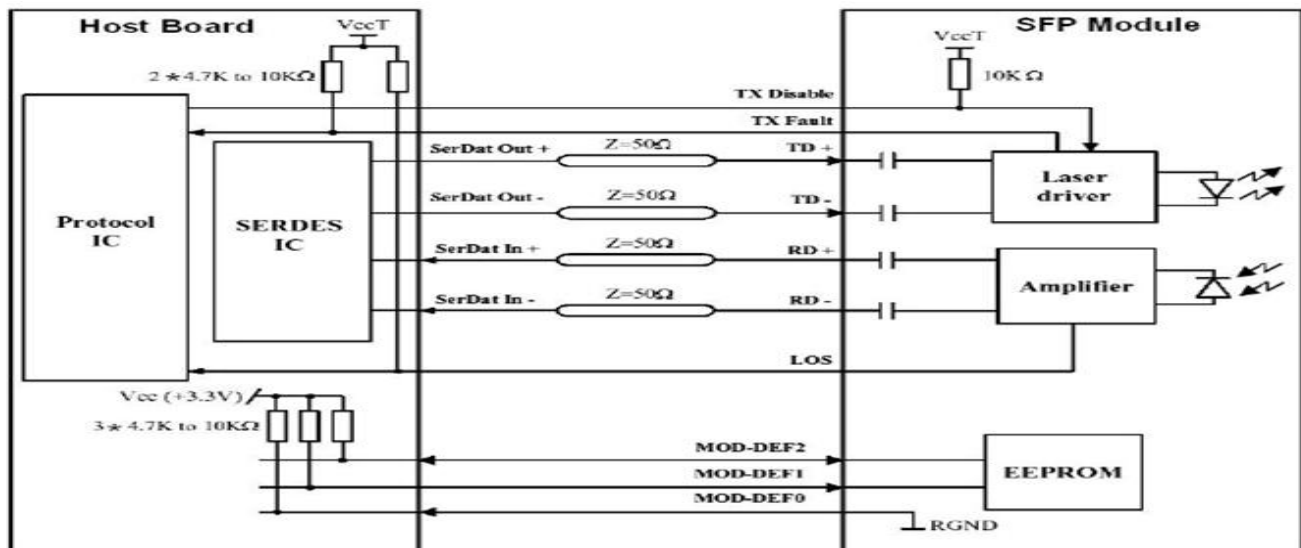

# 1.25Gbps 1550nm 100km SFP Optical Transceiver Module

## S-SP1G55LA0-xD

### Mechanical Dimensions

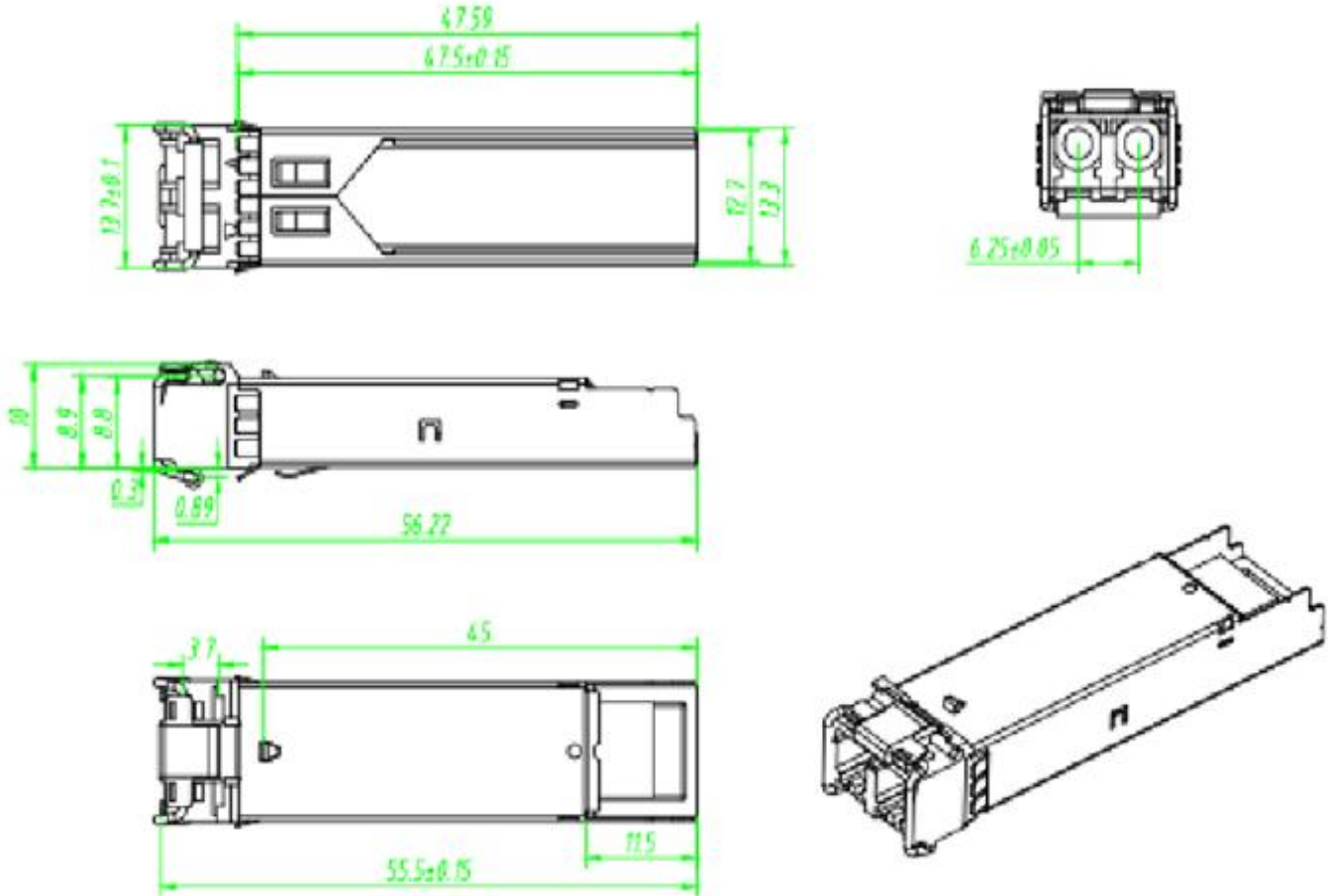

### Ordering information

Part Number	Product Description
S-SP1G55LA0-CD	SFP, 1.25Gbps, 1550nm, SM, 100km, 0°C~+70°C, With DDM
S-SP1G55LA0-ID	SFP, 1.25Gbps, 1550nm, SM, 100km, -40°C~+85°C, With DDM